



# INSTALLATION INSTRUCTIONS

Accessory  
XM RADIO SYSTEM

Application  
2011 CR-Z

Publications No.  
All 43569  
Issue Date  
AUG 2010

## PARTS LIST

**Attachment Kit**  
P/N 08B15-SZT-100

XM tuner bracket A

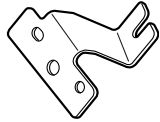

XM tuner bracket B

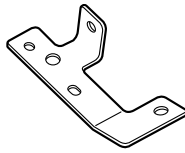

Bus cable

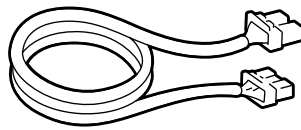

Clip



6 x 16 mm Washer-bolt

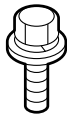

6 mm Plain washer



4 Hex bolts, 5 x 8 mm



4 Wire ties

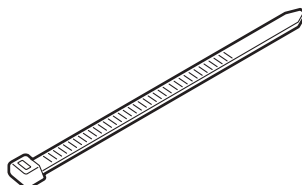

Wire tie with clip

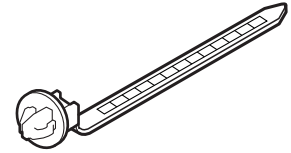

7 EPT sealers

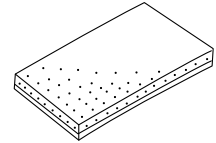

Cushion tape

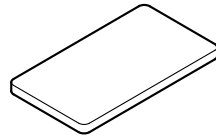

Cover seal

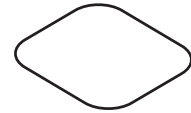

Accessory User's Information Manual

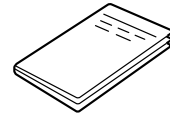

**XM Antenna Kit**  
P/N 08A15-0J1-100

Antenna

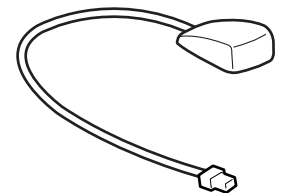

**XM Tuner Kit**  
P/N 08A15-3J1-001

XM tuner

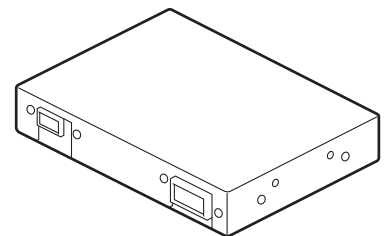

**Subharness (2-port)  
P/N 08A31-0F1-000**

Subharness

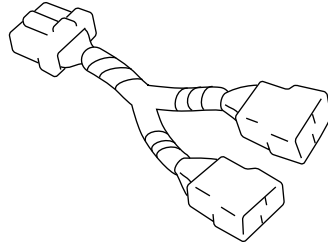

**TOOLS AND SUPPLIES REQUIRED**

- Phillips screwdriver
- Flat-tip screwdriver
- 10 mm Open end wrench
- Ratchet
- 8 mm and 10 mm Sockets
- Isopropyl alcohol
- Shop towel
- Rubber mallet
- Tape measure
- Scissors
- Masking tape
- Diagonal cutters
- Trim Tool Set (SOJATP2014)  
(Available through the Honda Tool and Equipment program. On the iN, click on: Service/Service Bay/Tool and Equipment Program, then enter the number under "Search." Or call 888-424-6857.)

**Illustration of the XM Radio System Installed on the Vehicle**

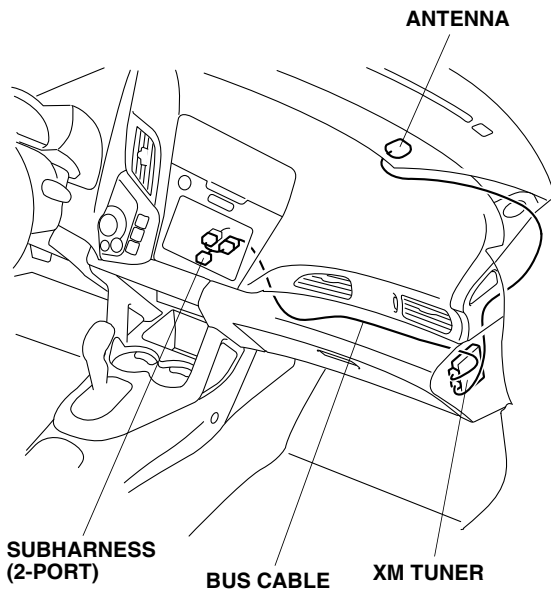

**INSTALLATION**

**Customer Information:** The information in this installation instruction is intended for use only by skilled technicians who have the proper tools, equipment, and training to correctly and safely add equipment to your vehicle. These procedures should not be attempted by "do-it-yourselfers."

1. Make sure you have the anti-theft code for the audio unit and navigation system (if equipped), then write down the radio station presets.
2. Disconnect the negative cable from the battery.
3. Pull away the door seal from around the passenger's A-pillar trim.

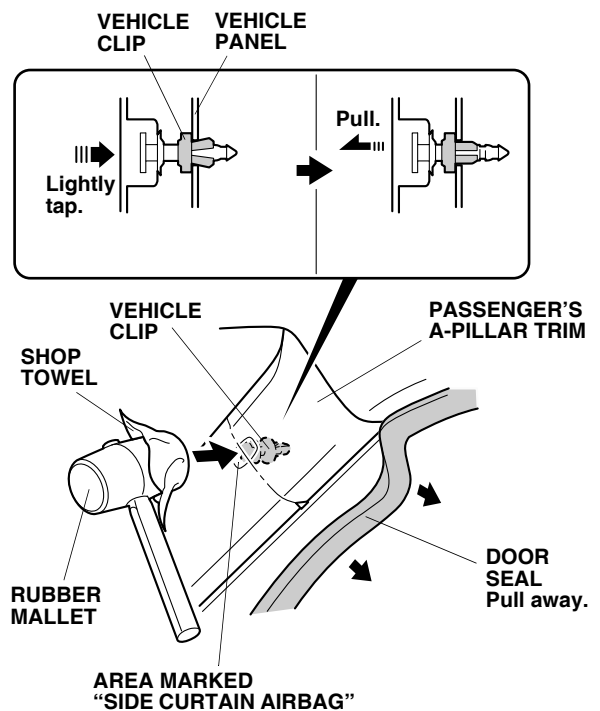

4. Using a rubber mallet wrapped with a shop towel, lightly tap the area marked "SIDE CURTAIN AIRBAG" on the top of the passenger's A-pillar trim to release the vehicle clip. Make sure to strike area perpendicular to the vehicle.

- Remove the passenger's A-pillar trim (two clips).

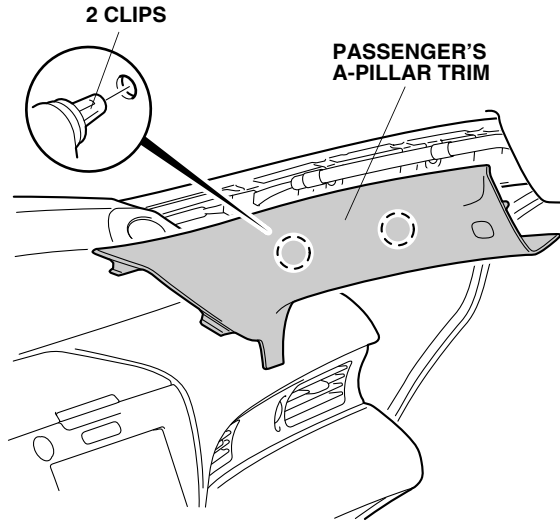

- Attach masking tape to the instrument panel in the area shown.

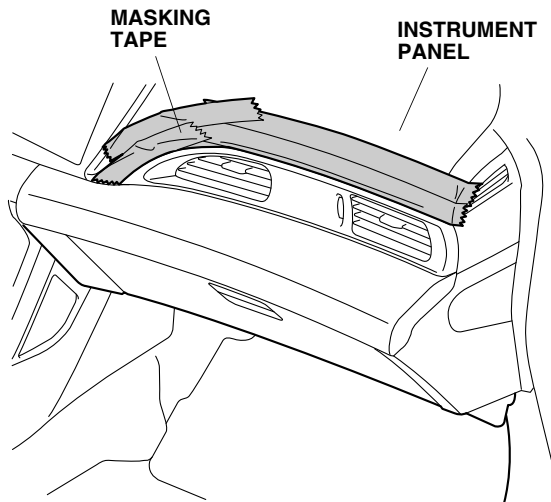

- Using a trim tool, release the passenger's dashboard vent (one clip and one retaining tab).

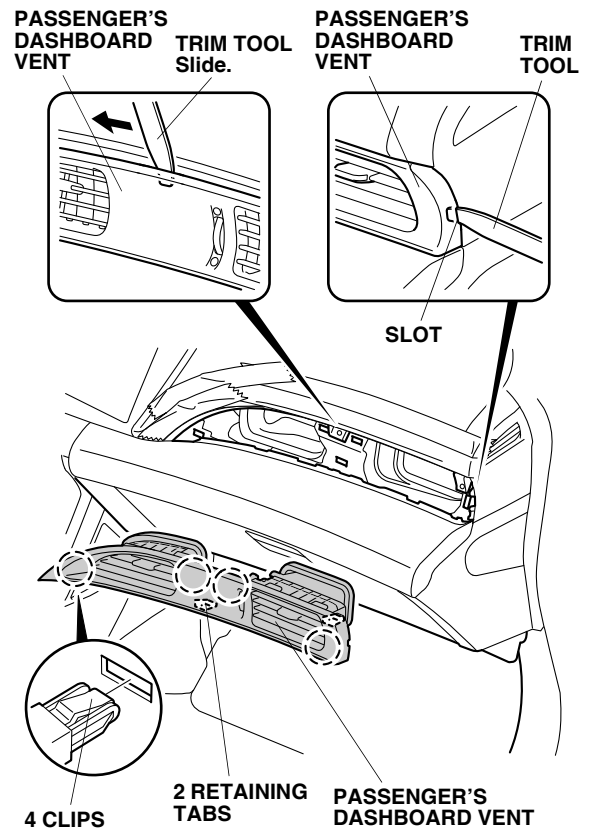

- Using a trim tool, remove the passenger's dashboard vent (three clips and one retaining tab).
- Remove the passenger's dashboard panel (eight clips).

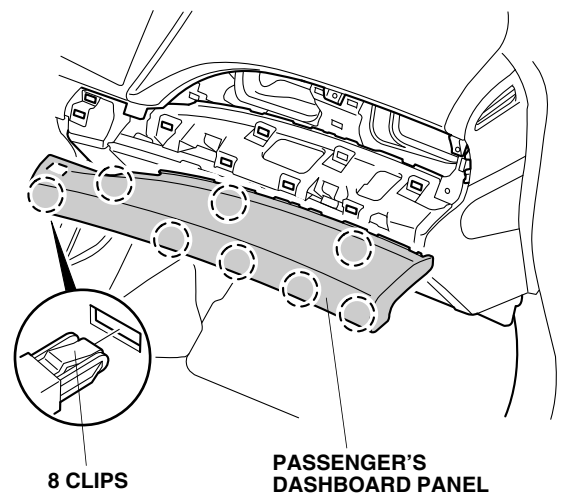

10. Remove the passenger's under cover (four clips and two pins). If equipped with the footwell lights, release the clip and unplug the vehicle connector.

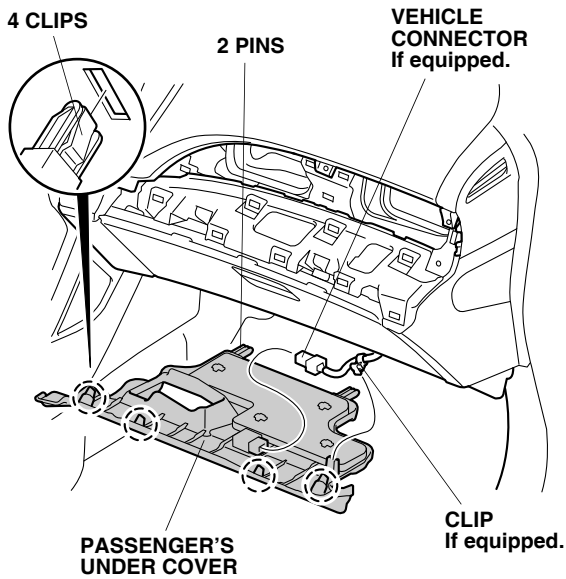

11. Remove the glove box (four bolts, two self-tapping screws, four clips, and release the light). Do not damage the light.

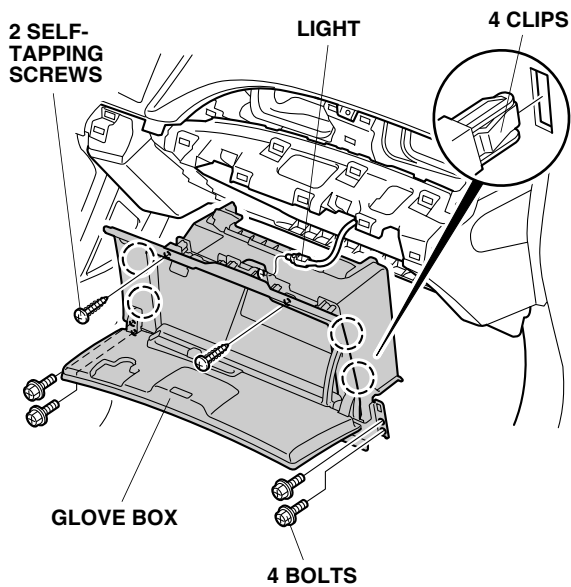

12. Pull away the door seal from around the passenger's kick panel, and remove the passenger's kick panel (two clips and three retaining tabs).

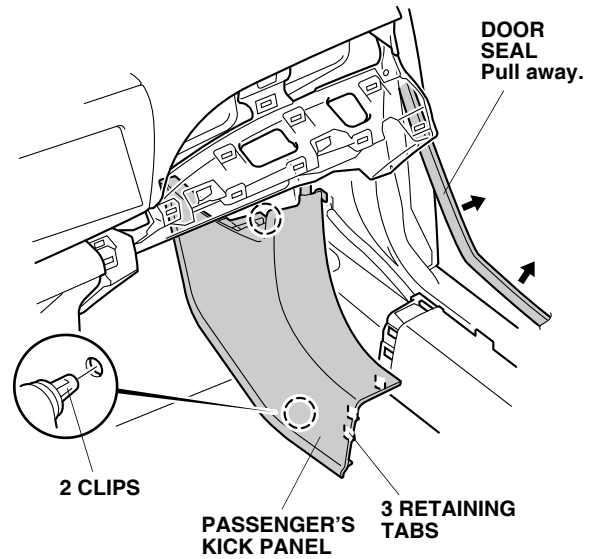

13. Remove the center lower lid (five retaining tabs, three hooks, and unplug the vehicle connector).

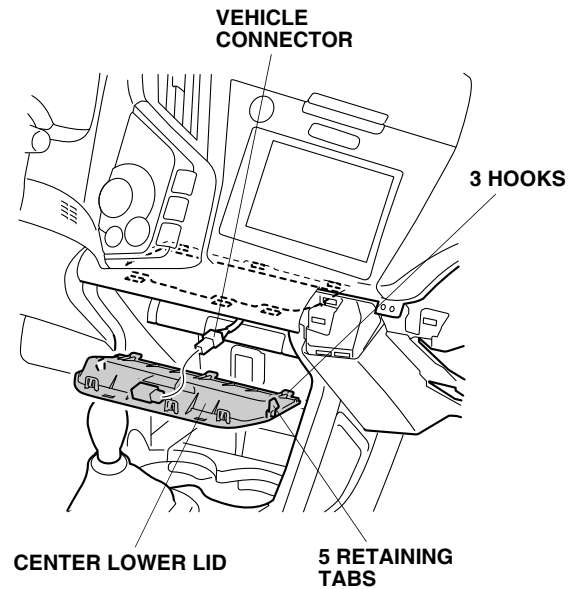

- Attach masking tape to the dashboard, the instrument panel, and the center trim.

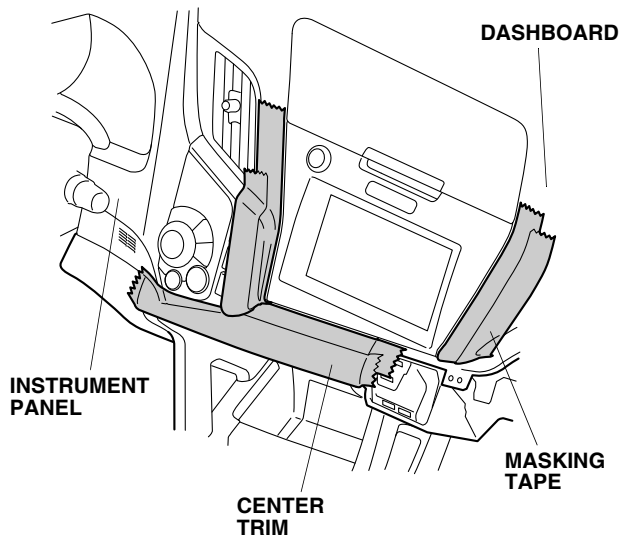

If the vehicle is equipped with a Navigation System, continue with step 15; otherwise, go to step 18.

#### With Navigation System

- Under the center panel, locate and remove the bolt that secures the navigation system.

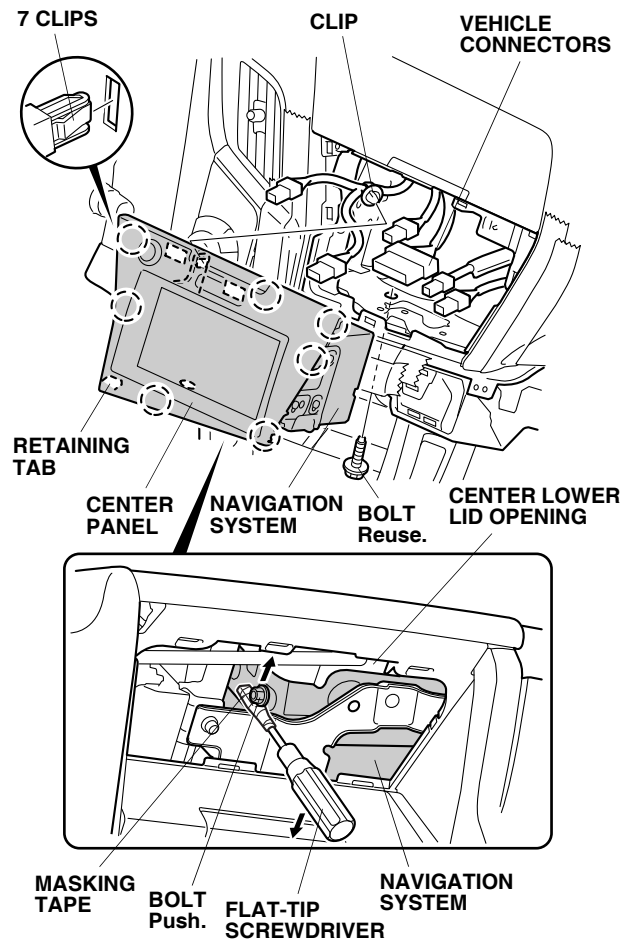

- Using a flat-tipped screwdriver wrapped with masking tape, release the center panel by pushing on the navigation system bolt to release the seven clips and one retaining tab. Do not damage the navigation system.
- Remove the center panel/navigation system (one clip and unplug the vehicle connectors), then go to step 21.

## Without Navigation System

- Under the center panel, locate and remove the bolt that secures the audio unit.

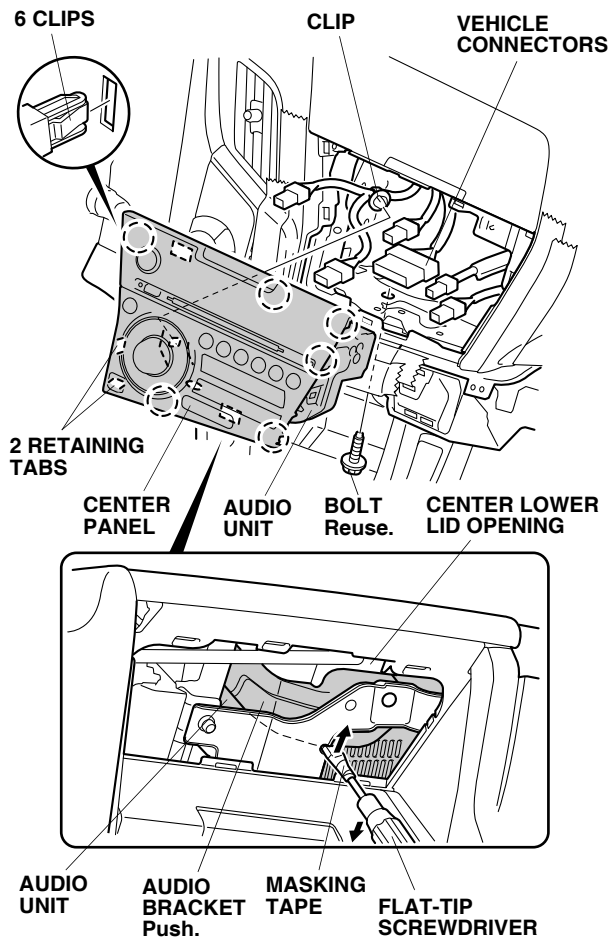

- Using a flat-tip screwdriver wrapped with masking tape, release the center panel by pushing on the audio bracket to disengage six clips and two retaining tabs. Do not damage the audio unit.
- Remove the center panel/audio unit (one clip and unplug the vehicle connectors).

## Installing and Routing the Antenna

- Using scissors, cut one EPT sealer in half. Wrap one cut piece of EPT sealer around the antenna lead in the area shown.

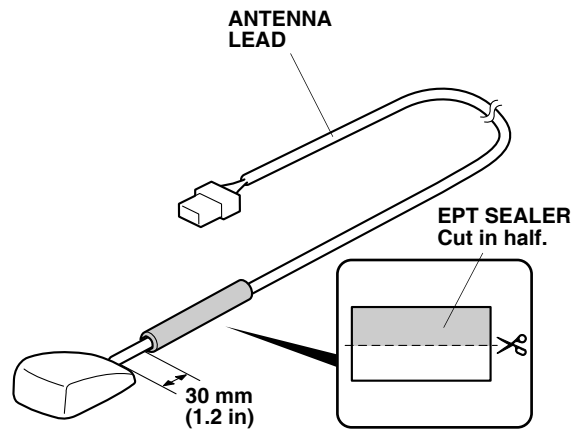

- Using isopropyl alcohol on a shop towel, thoroughly clean the inside of the windshield where the antenna will attach. Remove the four adhesive backings from the antenna, and attach the antenna to the windshield as shown. Firmly press the antenna against the windshield for 30 seconds.

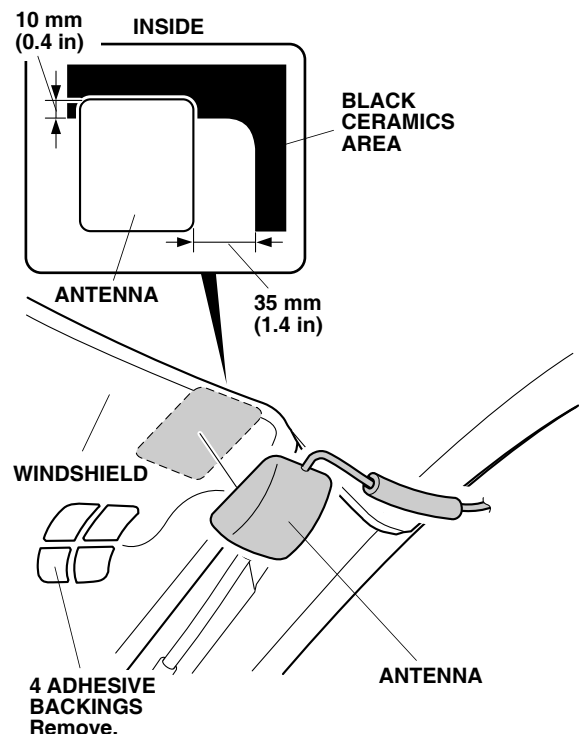

23. Using isopropyl alcohol on a shop towel, thoroughly clean the outside of the windshield where the cover seal will attach. Remove the adhesive backing from the cover seal, and attach the cover seal to the windshield as shown.

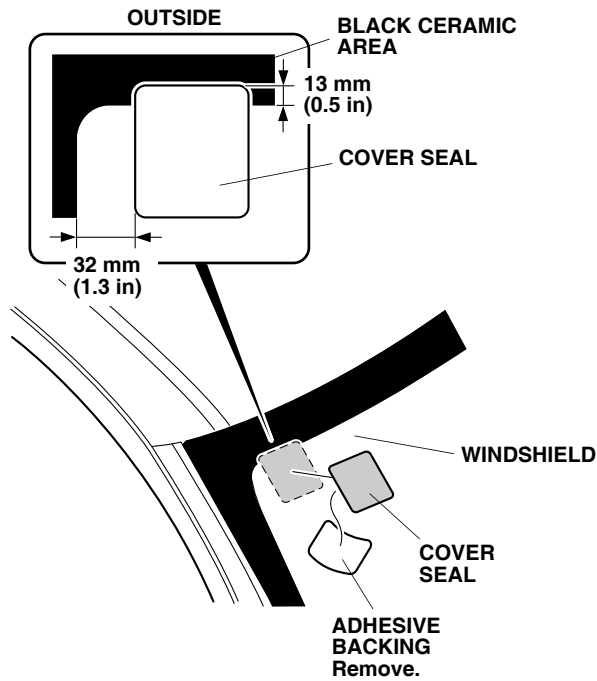

24. Gently insert the antenna lead between the vehicle panel and the headliner.  
NOTE: Be careful not to crease the headliner.

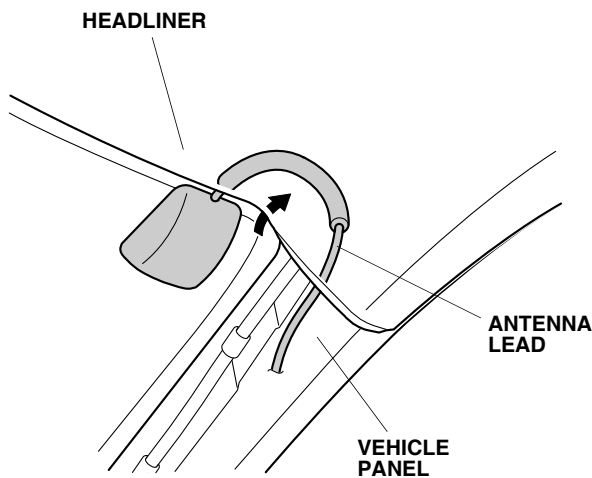

25. Using scissors, cut one cushion tape into four equal pieces.

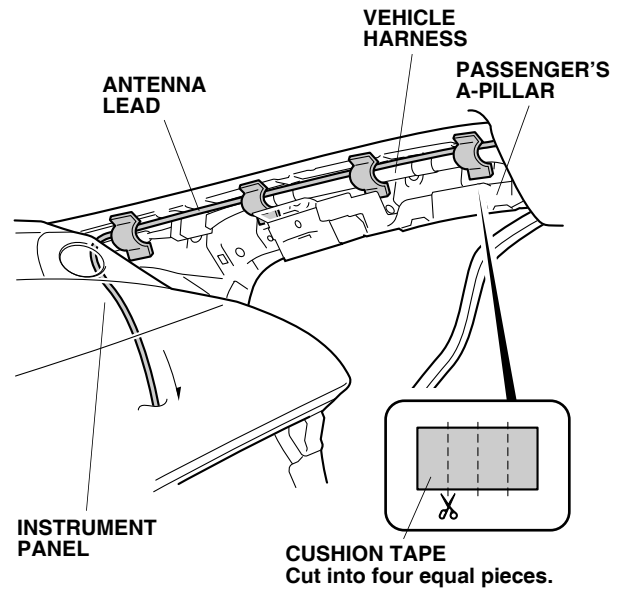

26. Using isopropyl alcohol on a shop towel, thoroughly clean the passenger's A-pillar where the cushion tapes will attach. Route the antenna lead down alongside the vehicle harness, and secure it to the vehicle harness with four pieces of cushion tape.
27. Using a piece of masking tape, mark the antenna lead where the antenna lead touches the dashboard.

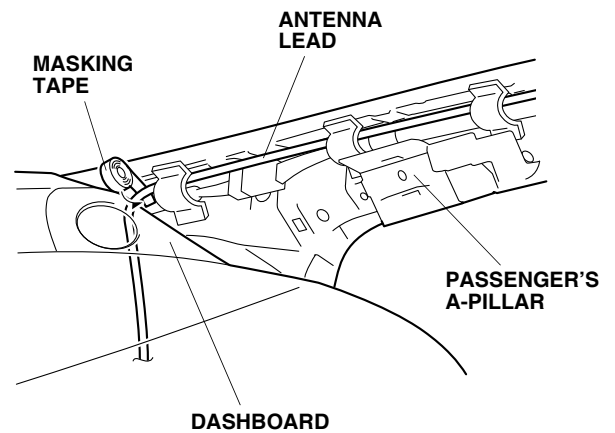

28. Using scissors, cut one EPT sealer in half. Wrap three pieces of EPT sealer (including the remaining piece from step 21) around the antenna lead from the masking tape down. Remove the masking tape.

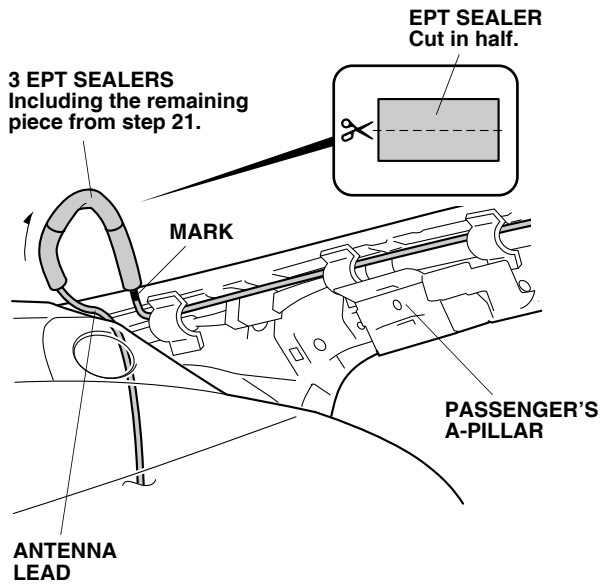

29. Route the antenna lead down through the glove box opening.

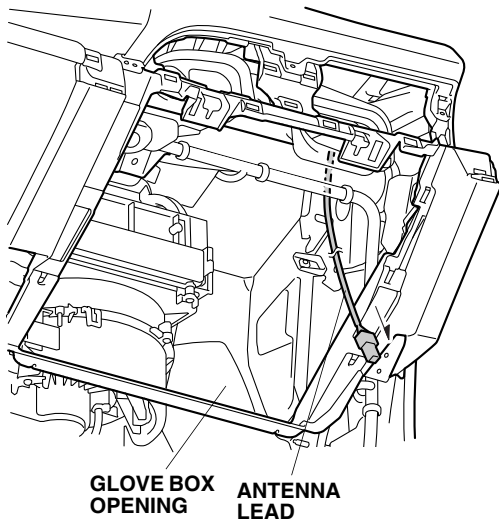

30. Bundle up the excess antenna lead, and loosely secure the antenna lead with one wire tie with clip as shown.  
NOTE: Do not bend the antenna lead more than the amount shown.

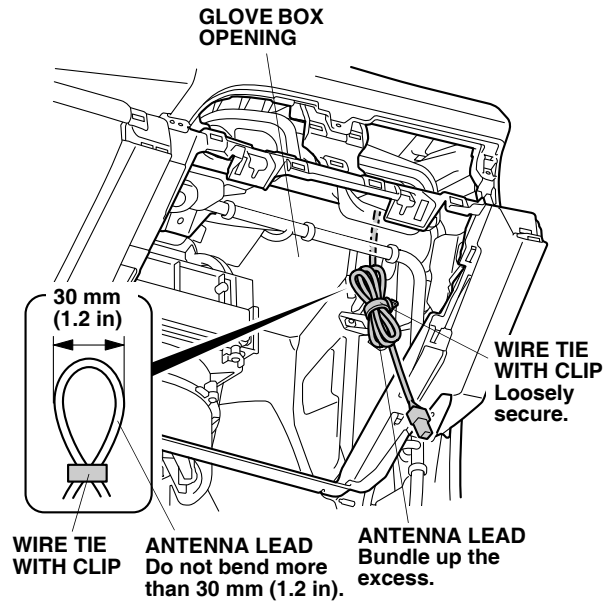

### Routing the Bus Cable

31. Wrap one EPT sealer around the bus cable in the area shown.

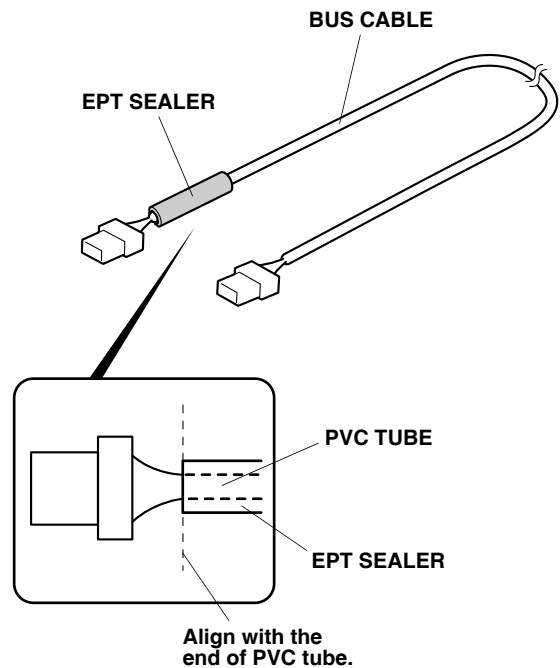



32. Route the bus cable from the glove box opening to the center panel opening.

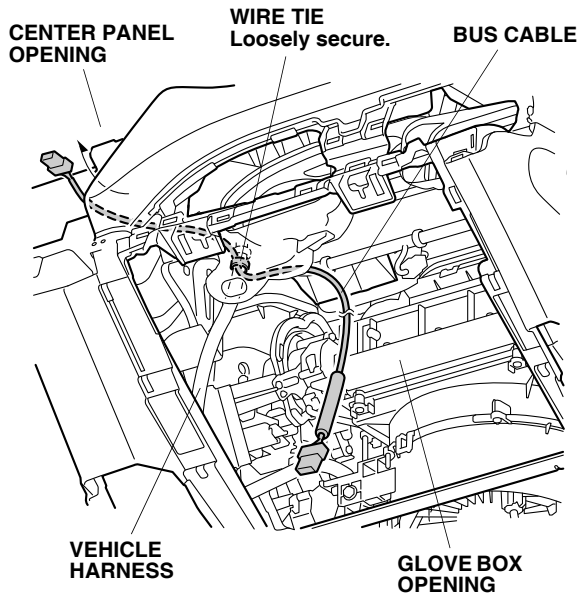

33. Loosely secure the bus cable to the vehicle harness with one wire tie in the area shown.  
 34. Route the bus cable along the vehicle harness.

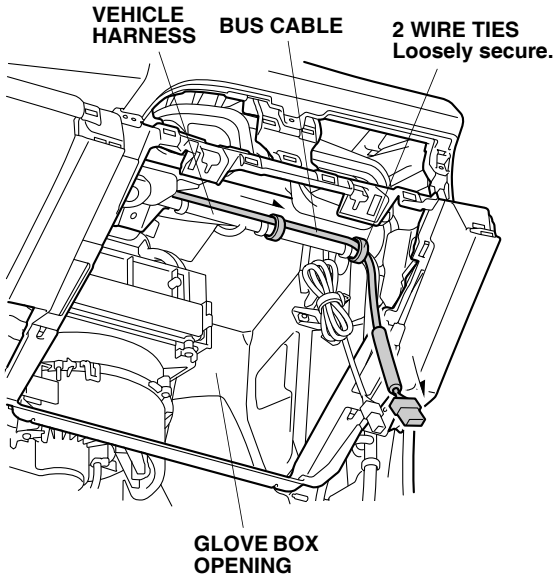

35. Loosely secure the bus cable to the vehicle harness with two wire ties in the areas shown.

### Installing the XM Tuner

36. Install XM tuner bracket A and bracket B onto the XM tuner with four 5 x 8 mm hex bolts.  
 NOTE: Be sure to install the brackets in the correct position and orientation.

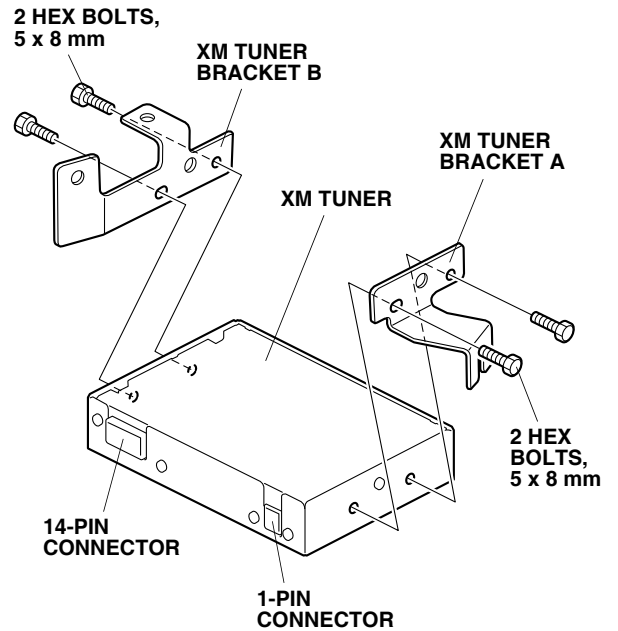

37. At the glove box opening, loosen the upper blower motor mounting nut.

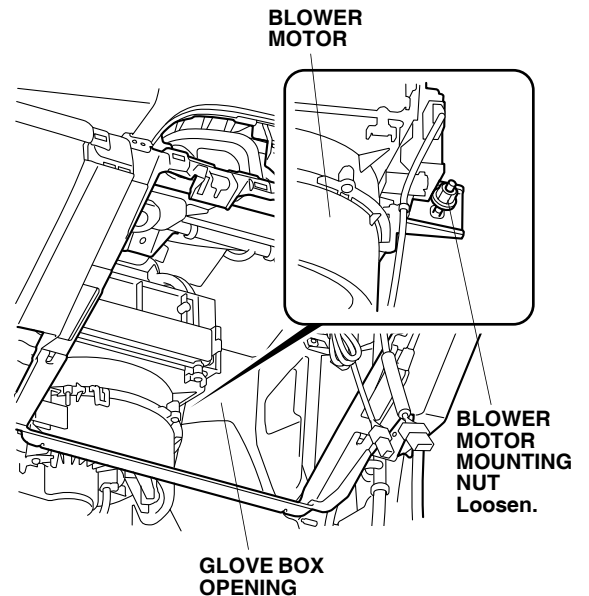

If the vehicle is an EX model, continue with step 38; otherwise, go to step 40.

38. Remove and discard the HFL control unit upper mounting bolt.

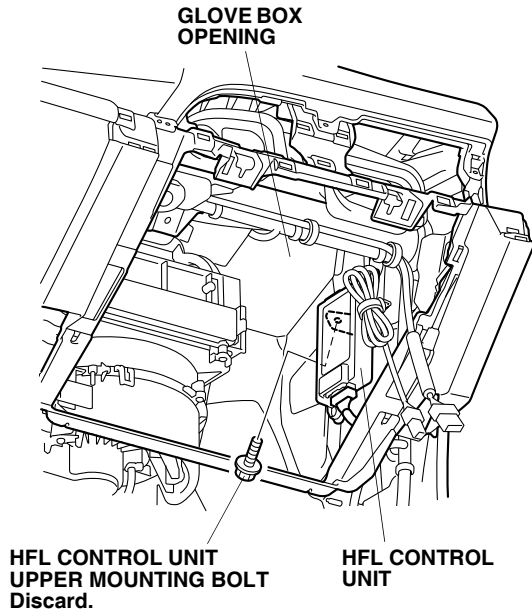

39. Install the 6 x 16 mm washer-bolt through the XM tuner bracket and the HFL control unit bracket into the vehicle panel. Secure the 6 x 16 mm washer-bolt and the blower motor mounting nut. Go to step 41.

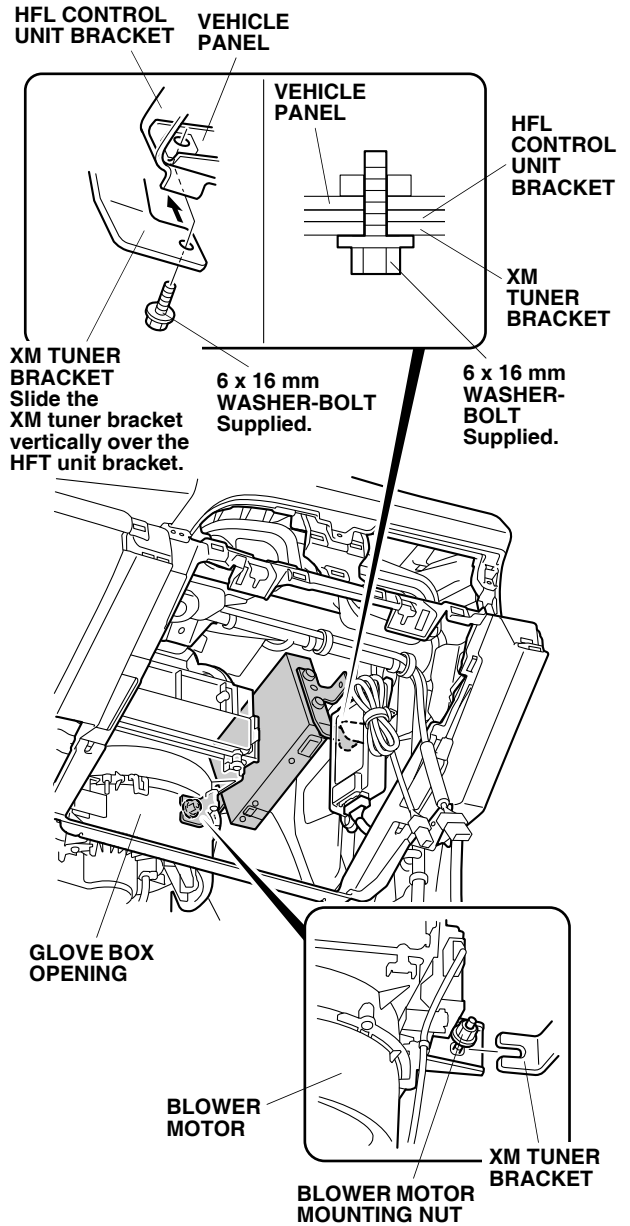

40. Install the 6 x 16 mm washer-bolt through the XM tuner bracket into the vehicle panel. Secure the 6 x 16 mm washer-bolt and the blower motor mounting nut.

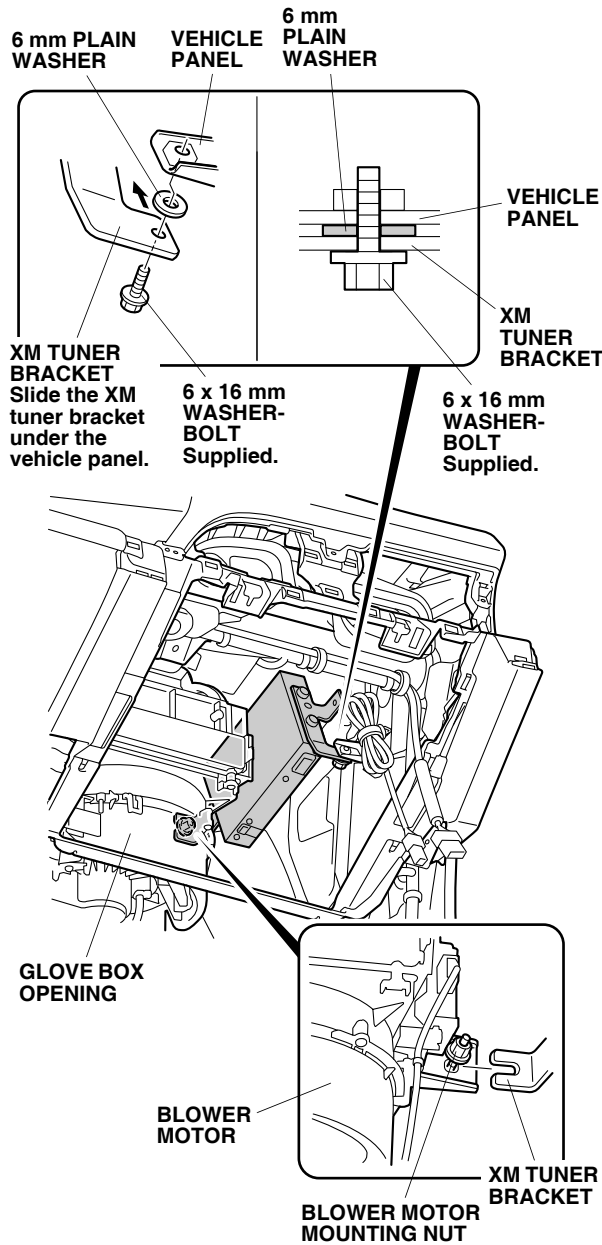

41. Plug the bus cable 14-pin connector and the antenna 1-pin connector into the XM tuner.

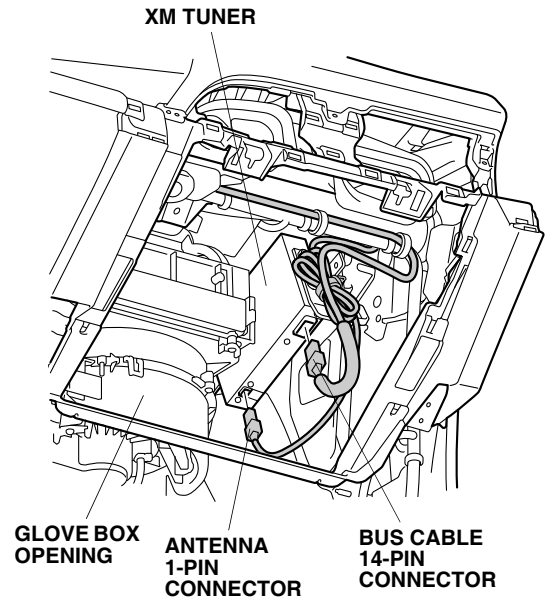

42. Secure the antenna lead and the bus cable to the XM tuner bracket with one wire tie with clip loosely installed to the antenna lead in step 30.

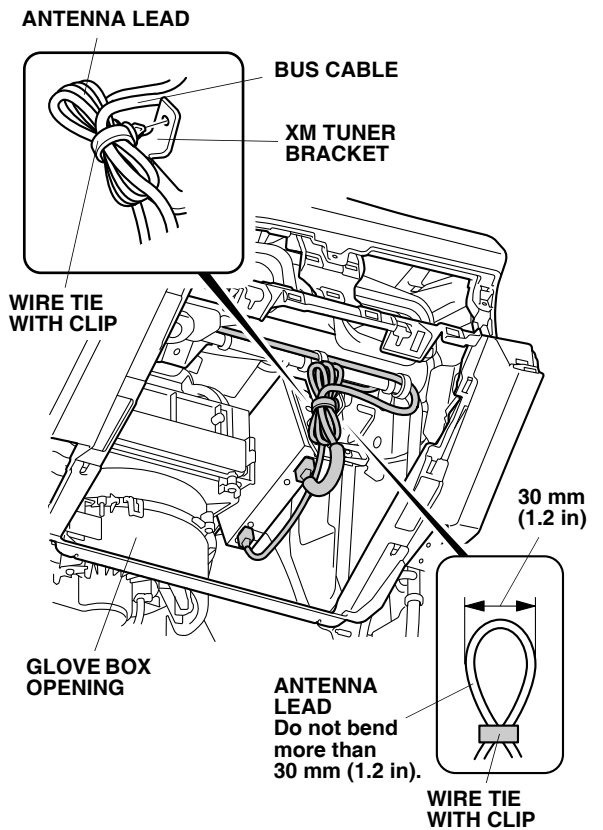

43. Secure the bus cable to the vehicle harness with three wire ties loosely installed in steps 33 and 35.

44. Plug the bus cable 14-pin connector and the vehicle 14-pin connector into the subharness (2-port) 14-pin connectors. Wrap one EPT sealer around each 14-pin connector.

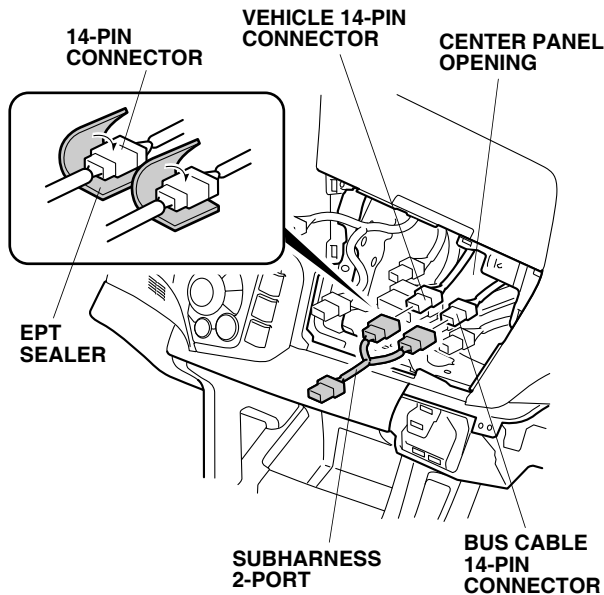

45. Plug the subharness (2-port) 14-pin connector into the navigation system/audio unit, and reinstall the center panel.

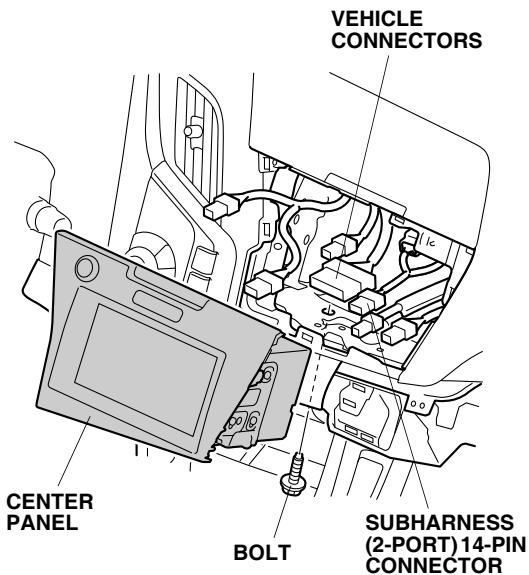

46. Remove the vehicle clip, and install the new clip to the passenger's A-pillar trim.

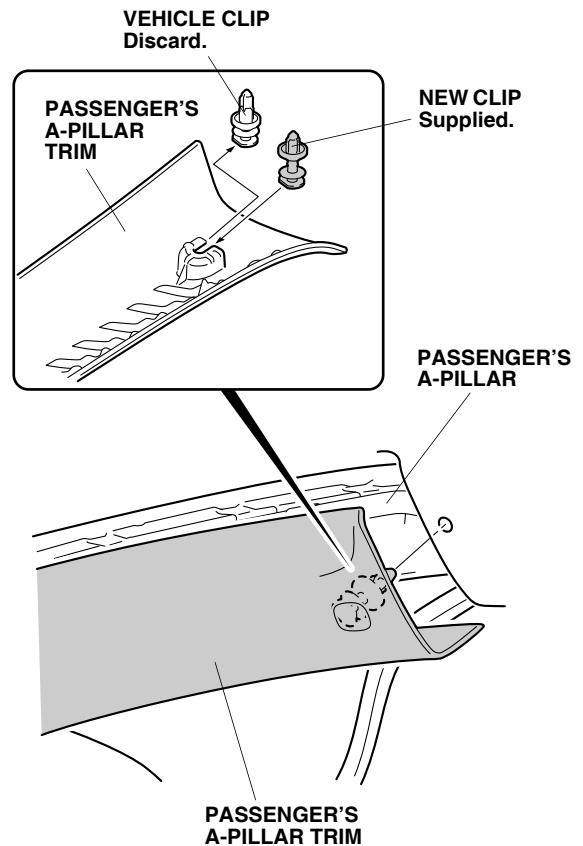

47. Reinstall the passenger's A-pillar trim.
48. Check that all wire harnesses are routed properly and all connectors are plugged in.
49. Reconnect the negative cable to the battery.
50. Enter the customer's anti-theft code for the audio unit and navigation system (if equipped), and reset the radio station presets.
51. Reset the clock.
52. Check the operation of the XM radio system according to the Accessory User's Information Manual supplied.
53. Reinstall all removed parts.
54. If the IMA battery level gauge display is at zero, start the engine, and hold it between 3,500 rpm and 4,000 rpm (without load) in P or N position until the IMA battery level gauge display shows at least half-charged.